



UNIVERSITY OF
CAMBRIDGE

Multi-Tenant Programmable Network Switches

Radostin Stoyanov and Noa Zilberman

3rd P4 Workshop in Europe (EuroP4) - December 2020

Applications developed on programmable network devices

- **Consensus:** P4xos, NetPaxos, NOPaxos
- **DNS:** P4DNS
- **Concurrency control:** Eris
- **Load balancer:** SilkRoad
- **Traffic monitoring:** In-band Network Telemetry, SketchLearn, Elastic sketch, BurstRadar
- **Caching:** LaKe, NetCache, IncBricks
- **Storage:** NetChain, SwitchKV
- **Machine learning:** IIsy, SwitchML, NetAccel
- **Access control:** P4Guard, P4Knocking, P4ID

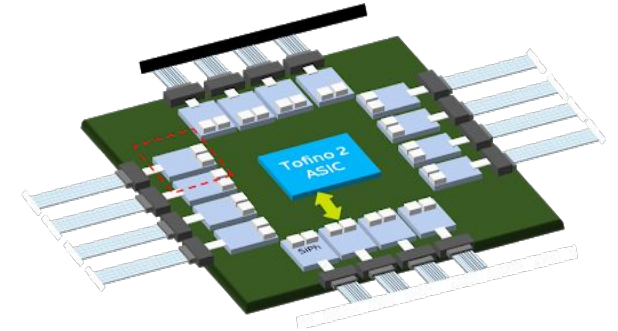
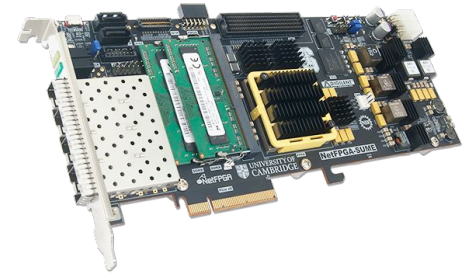

PDP Virtualization and Multi-Tenancy

Requirements:

- Security isolation
- Performance isolation
- Resource isolation
- On-the-fly reconfigurability

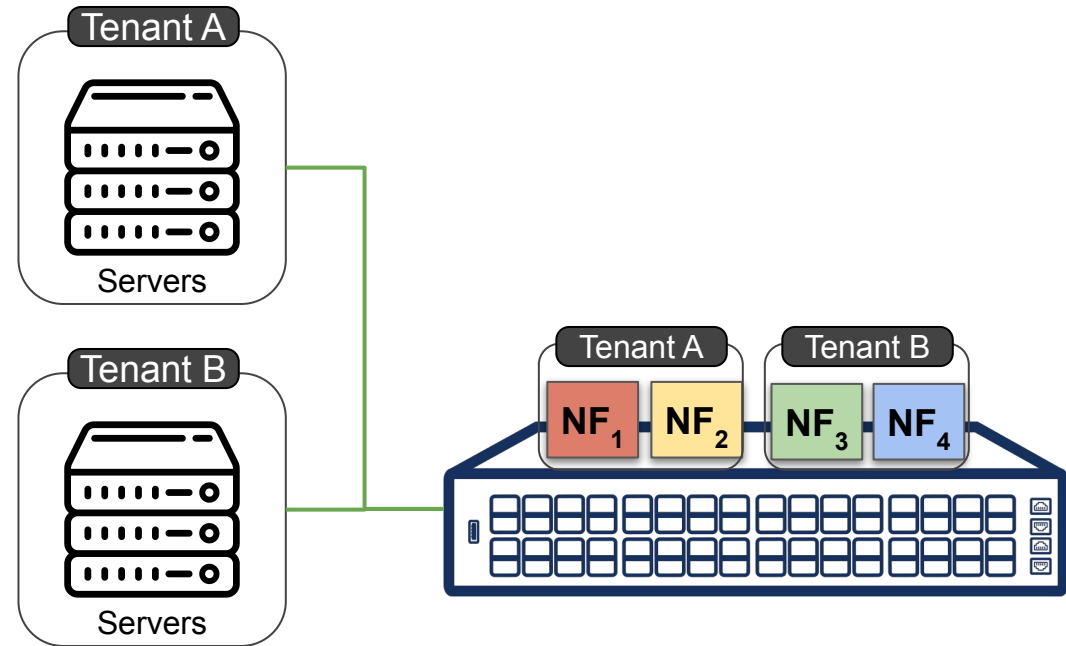

How a malicious user can take advantage of multi-tenancy?

A malicious programs can:

- Recirculate packets into the pipeline
- Loopback packets through multiple devices
- Clone & recirculate a packet infinite amount of times

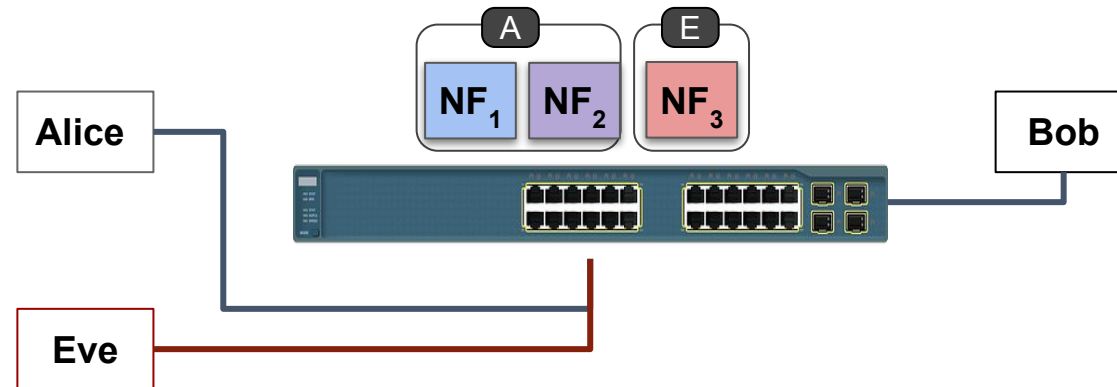

Operating Model

Packet pre-processing and post-processing:

- Encapsulation (VxLAN)
- Separation of pipelines

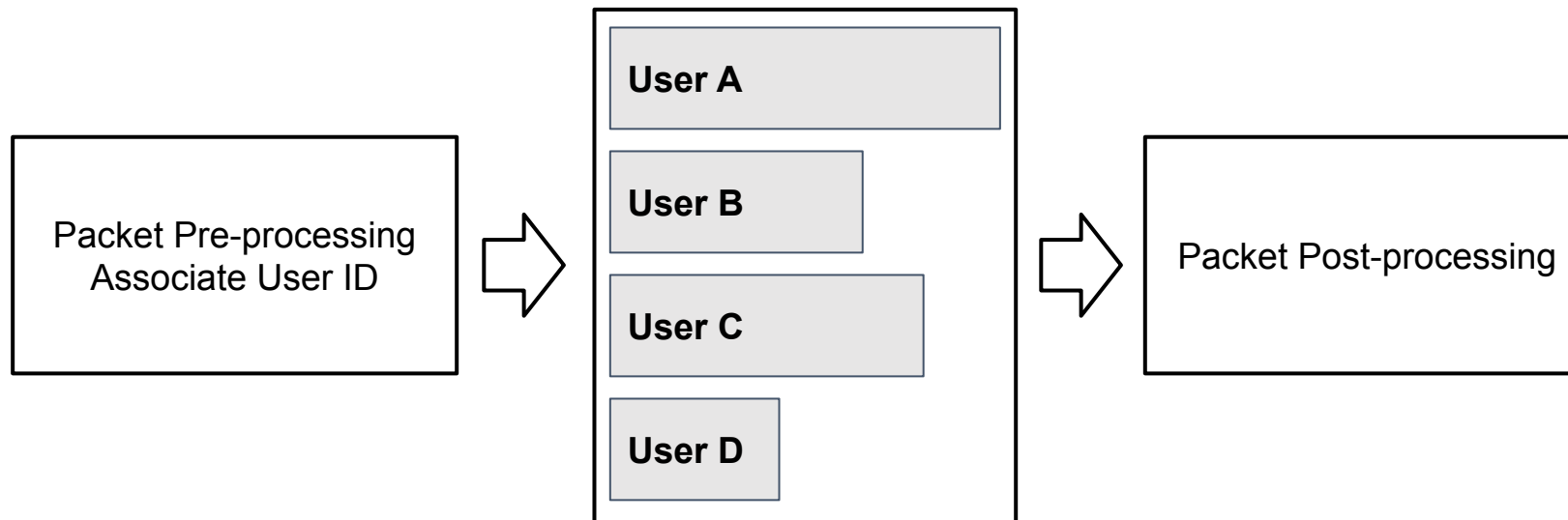

Roles & Permissions

Roles - defines an authority level

- Users
- Superuser
- Custom roles (M/A rules set by Superuser)

Permissions - an approval of a mode of access to a resource

- Externs (Internet Checksum, Random)
- Packet cloning
- Recirculation
- Multicast
- Registers



MTPSA

- Superuser vs User architecture
- User isolation:
 - Security (ACL, VXLAN)
 - Performance (QoS)
 - Resource (Switch Context)

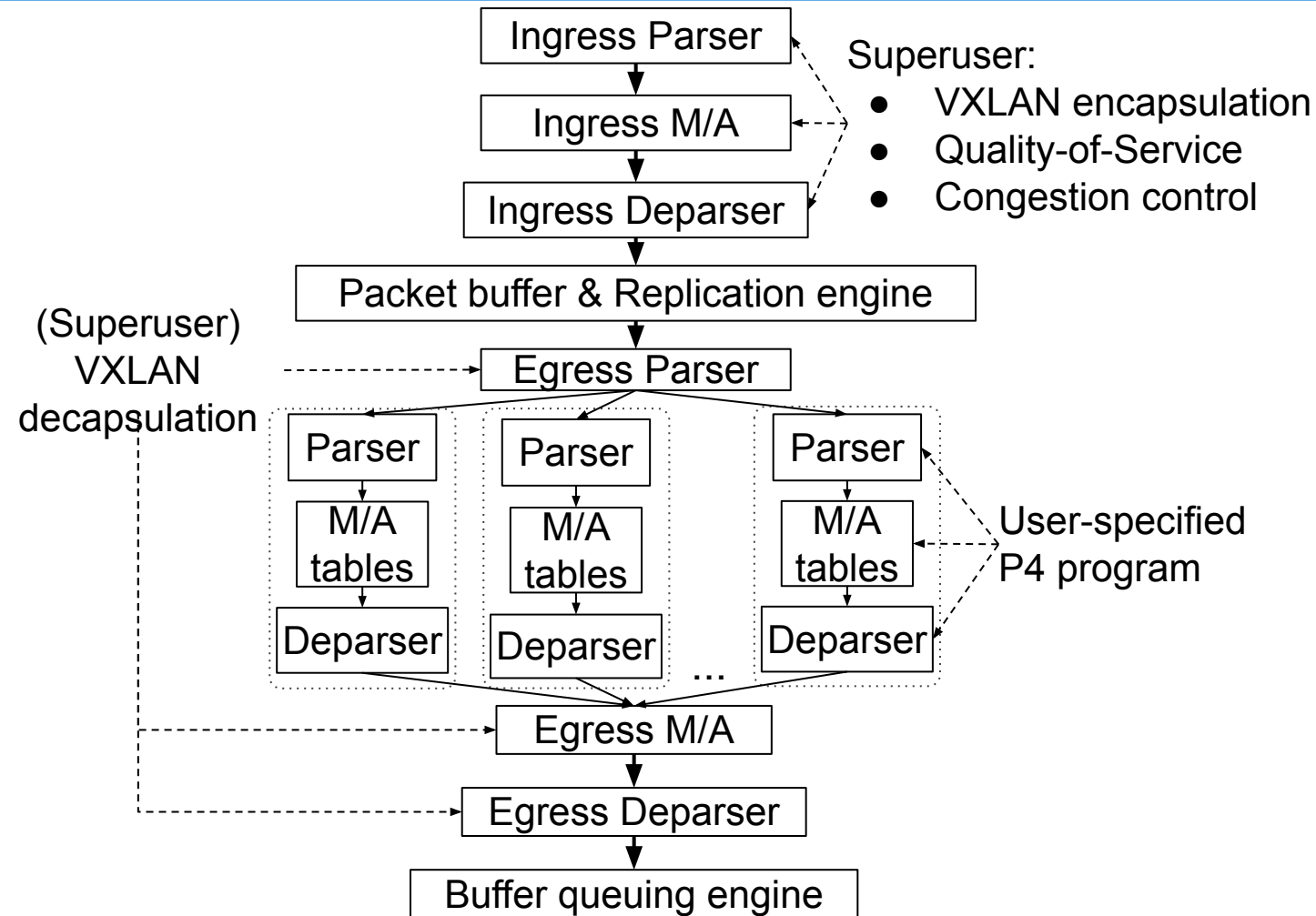

BMv2 MTPSA

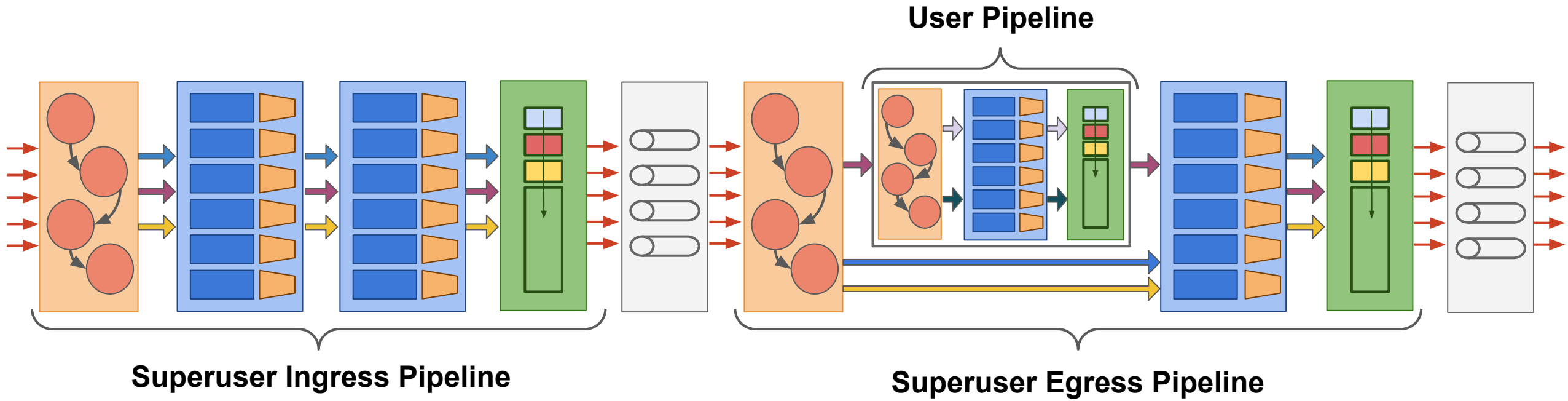

P4→NetFPGA MTPSA

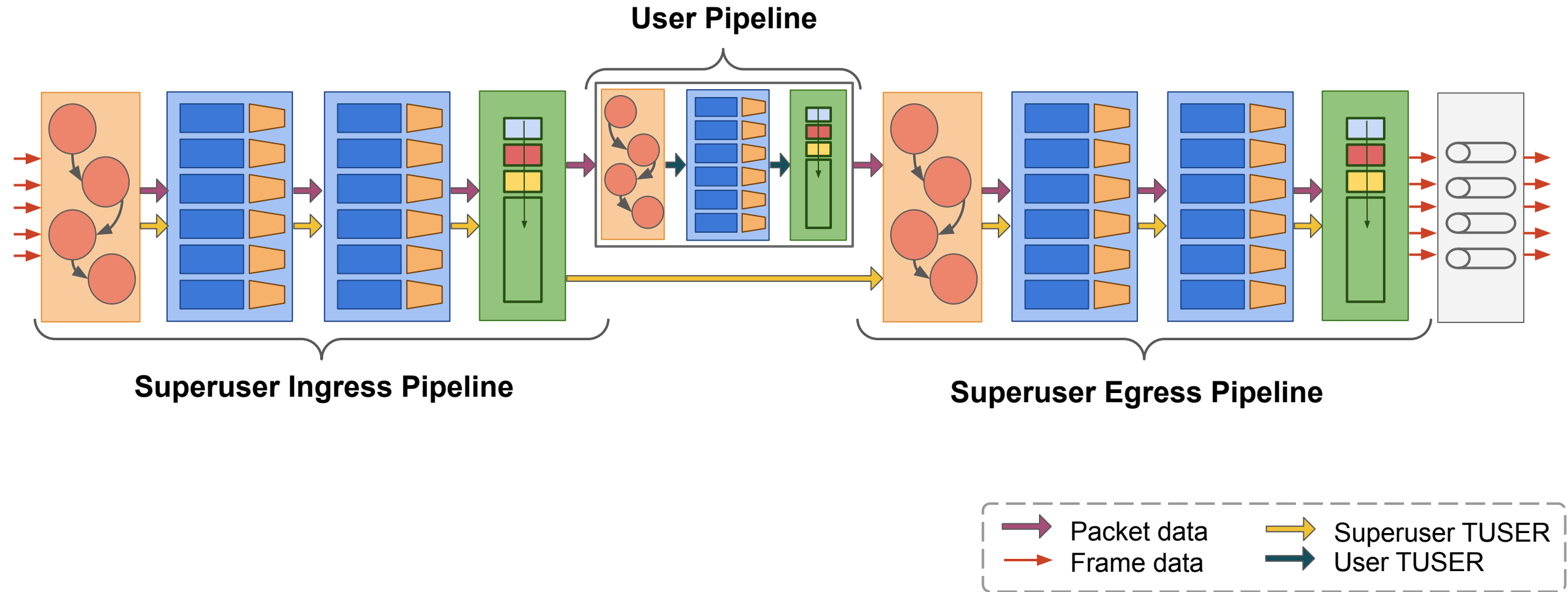

Questions?

Benefits of MTPSA

- Constant latency
- Performance, resource and security isolation
- Hardware feasibility

<https://github.com/mtpsa>

